



“Computer Hardware,  
Electronics, Repairment and  
Maintenance”

By Er. Prashant Shrestha



## Unit 1 Introduction to Electronic devices

### 1.1 Matter, Molecule, and atom

#### a) Matter

Matter is anything that has mass and occupies space. It makes of everything in the universe; from the air we breathe to the solid object we can touch. Matter exists in three primary states that are solid, liquid and gas depending upon temperature and pressure.

#### b) Molecule

A molecule is a group of two or more atoms bonded together. Molecules can be made up of the same type of atom like oxygen  $O_2$ , or different types of atoms like water  $H_2O$ . The atoms within a molecule are held together by chemical bonds.

#### c) Atom

Atom is the smallest unit of matter that retains the properties of an element. It consists of a nucleus (Made up of protons and neutrons) surrounded by electrons in orbitals. Atoms combine to form molecules, and each element is made up of one type of atom. For example, a water molecule ( $H_2O$ ) is made up of two hydrogen atoms and one oxygen atom.

#### Structure of atom

The structure of an atom consists of three subatomic particles which are protons, neutrons and electrons.

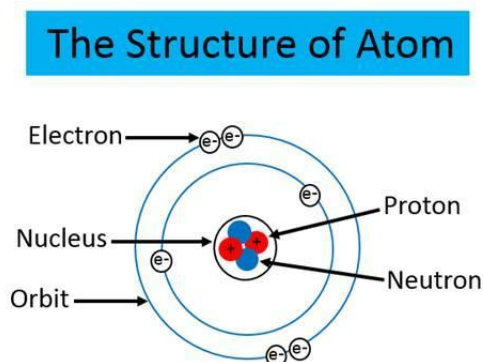

#### Nucleus

At the center of the atom, there is a dense core called the nucleus. The nucleus contains two types of subatomic particles which are described below

#### Protons:

Protons have a positive charge (+) and are located in the nucleus. The number of protons in the nucleus determines the atomic number and identity of the element.

## Neutrons:

These are neutral particles (no charge) that are also found in the nucleus. Neutrons and protons have approximately the same mass.

## Electrons:

These are negatively charged (-) and orbit the nucleus in energy levels or electrons shells. Electrons have much less mass compared to protons and neutrons.

## 1.2 Introduction to KCL and KVL

### a) Kirchhoff's Current law (KCL):

Kirchhoff's Current Law states that "the total current entering a junction or node in an electrical circuit is equal to the total current leaving the node." This law is based on the principle of conservation of charge. In other words, Kirchhoff's law states that "the algebraic sum of all currents at any node or junction is zero."

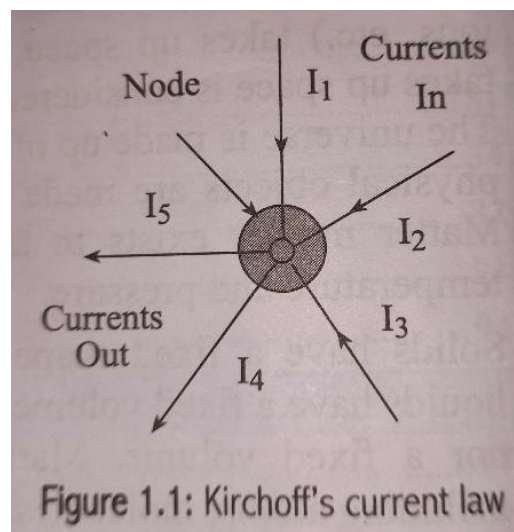

For a given figure shown above, applying Kirchhoff's current law at node, we get,

$$I_1 + I_2 + I_3 = I_4 + I_5$$

$$\text{Or, } I_1 + I_2 + I_3 - I_4 - I_5 = 0$$

$$\therefore I_1 + I_2 + I_3 - I_4 - I_5 = 0$$

Now generalized equation for KCL becomes,

$$\sum_{K=1}^n \mathbf{I}_K = 0$$

## b) Kirchoff's Voltage Law (KVL)

Kirchoff's Voltage Law states that "the sum of all voltages around a closed loop in circuit is always equal to zero." This law is based on energy conservation which means the components in the loop completely use the total energy supplied by the sources

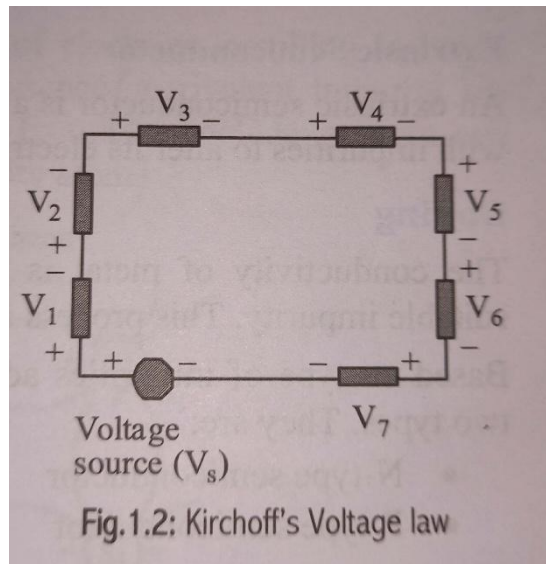

For the figure shown above, applying KVL, in loop we get,

$$V_1 + V_2 + V_3 + V_4 + V_5 + V_6 + V_7 = V_s$$

$$\text{Or, } V_1 + V_2 + V_3 + V_4 + V_5 + V_6 + V_7 - V_s = 0$$

$$\therefore V_1 + V_2 + V_3 + V_4 + V_5 + V_6 + V_7 - V_s = 0$$

The generalized equation for KVL given below

$$\sum_{K=1}^n V_K = 0$$

## 1.3 Introduction to Semiconductor Material

### Electronic device

Electronic devices are the components that are used to control the flow of current for the purpose of information passing and system control. Example, transistors, diode, etc.

### Semiconductor

Semiconductor is a material that has its conductivity somewhere between the insulator and conductor. They are used in many electronic devices, such as computers and phones.

## Forbidden gap in Semiconductor

The energy band between the valence band and conduction band is called forbidden band gap or forbidden energy gap.

## Valence band

The range of electron energy where the electron remains bounded to atoms and do not contribute to the electric current is known as valence band.

## Conduction band

The range of electron energies higher than valence band where electrons are free to accelerate under the influence of external voltage source resulting flow current is known as Conduction band

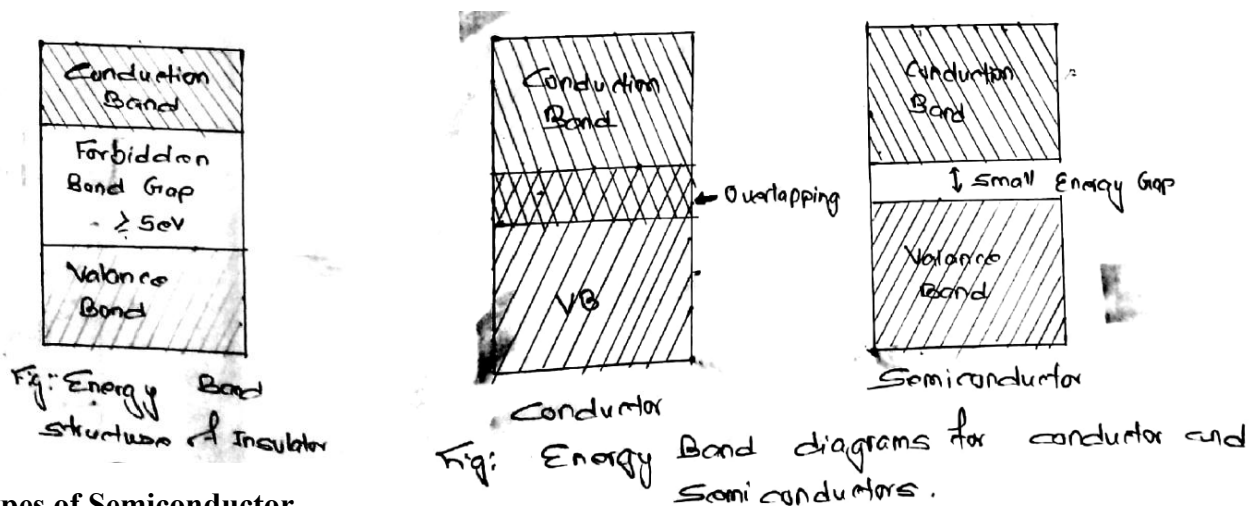

## Types of Semiconductor

There are two types of semiconductor conductors. They are

- a) Intrinsic semiconductor
- b) Extrinsic semiconductor

### a) Intrinsic semiconductor

An intrinsic semiconductor is a pure semiconductor, which means it does not have any impurities added to it. In an intrinsic semiconductor the number of free electrons and holes are equal. Under normal conditions (room temperature that is 25° Celsius), it behaves like an insulator, but when an electric field is applied, it can conduct electricity. Silicon (Si) and Germanium (Ge) are examples of intrinsic semiconductor.

## b) Extrinsic semiconductor

An extrinsic semiconductor is a type of semiconductor in which impurities are doped to alter electrical properties.

### Doping

The process of adding impurities to a pure semiconductor to increase the conductivity is known as doping.

### Types of extrinsic semiconductor

Based on impurities added, Extrinsic semiconductor are classified into two types they are:

#### a) N-types semiconductor

When pentavalent impurities Such as Arsenic, Antimony, Bismuth, phosphorus, etc. are added to the pure semiconductor then it is called N-type semiconductor.

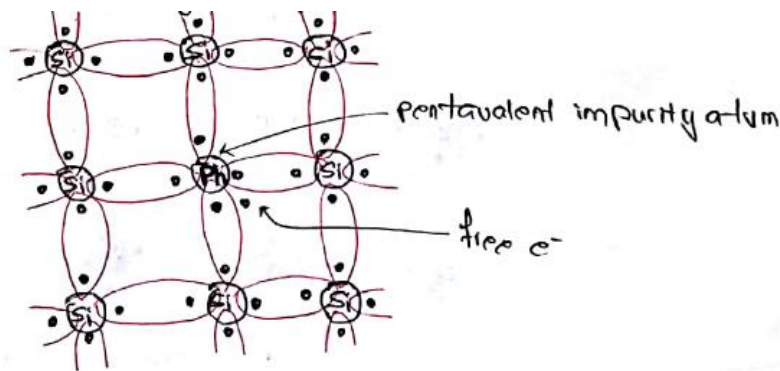

Fig: Crystal structure of N type semiconductor

When pentavalent element is doped, it creates an excess of free electrons, making it negatively charged and hence these electrons are involved in conduction of current.

#### P type semiconductor

When trivalent impurities such as aluminum, Gallium, Boron, etc. is added to pure semiconductor then it is known as P-type semiconductor.

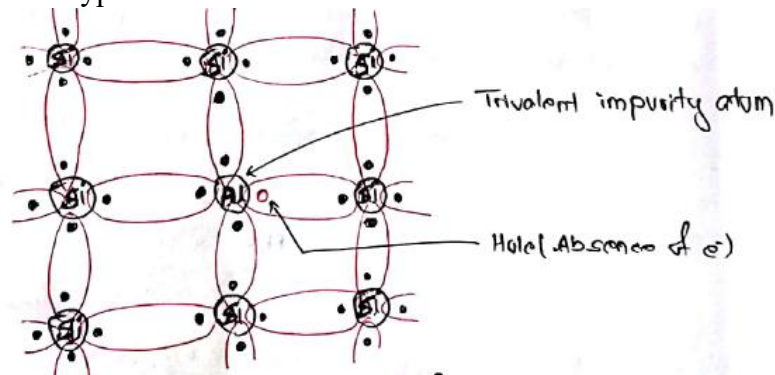

Fig: P-type semiconductor

The three valence electrons of the trivalent impurity form 3 covalent bonds with the neighboring atoms and a vacancy exists in fourth bond giving rise to the holes, which can accept the electron. So, trivalent impurities are also called acceptor impurities or acceptor agents.

### Majority and minority charge carriers

Majority carriers are the most abundant type of charge carrier in semiconductors. They are created by doping the semiconductor with impurities that are either introduced excess electron (N-type) or create vacancies for electron (P-type).

In other hand, minority carriers present in smaller quantities than majority charge carriers. They are created by thermal expansion or by the action external sources such as light.

In N-TN semiconductors, free electrons are majority charge carrier whereas holes are minority charge carrier.

Likewise in P-type, holes are majority charge carriers whereas free electrons are minority charge carriers.

### 1.4 PN junction formation, Forward Bias, and Revers bias

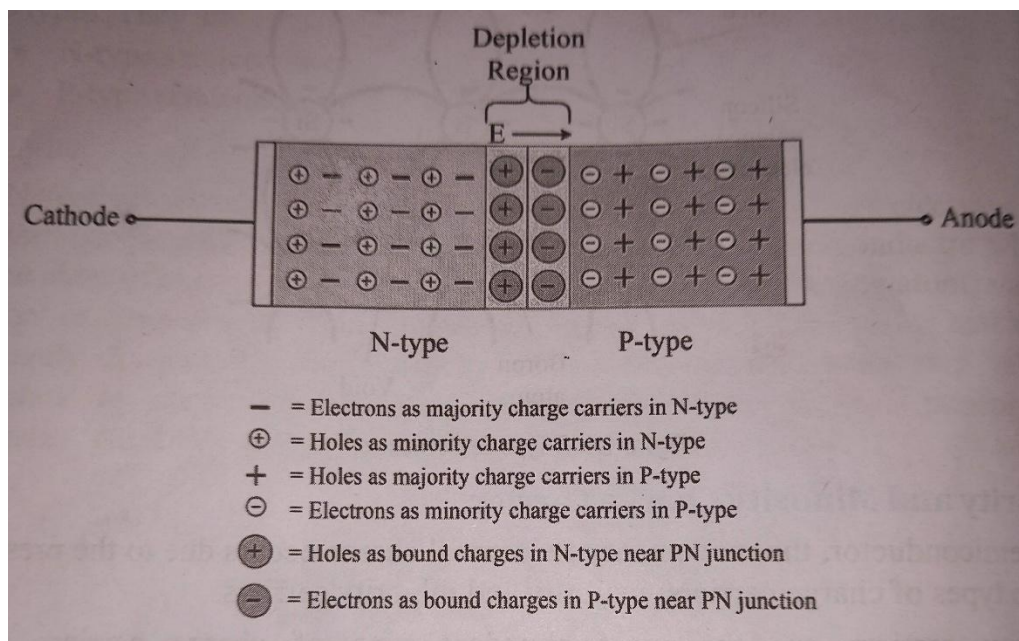

When a block of P-type semiconductor is joined with the block of N-type semiconductor, then a junction is formed in between them, which is called **PN junction**.

### Formation of PN junction

When the P type and N type region are brought into contact, the diffusion process occurs. Electrons from the N type region diffuse into the P-type region, and holes from the P type region diffuse into the N-type region. This diffusion process creates a region of charge carrier near the interface of the P-type and N-type regions, called the depletion region.

## Forward bias

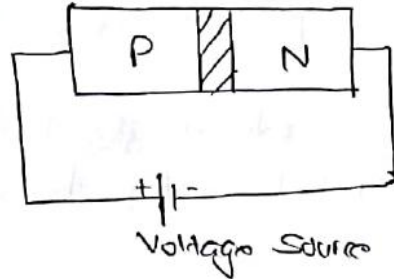

When p-type region of PN junction is connected to positive terminal of a source and N-type region is connected to negative terminal of a source, then it is called as forward bias. PN junction conducts current when it is connected in forward bias

## Reverse Bias

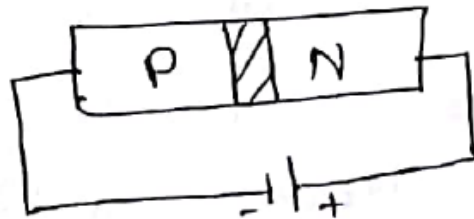

When p-type region of PN junction is connected to negative terminal of source and N-type region is connected to positive terminal of a source, then it is called as reverse bias. PN junction cannot conduct current when it is connected in reverse bias.

## Unit 2 Introduction to computer system

### 2.1 introduction to components of computer system

Computer is an electronic device that takes raw data as input from users process it and process output (information).

Components of computer systems are:

- i. Input unit
- ii. Processing unit
- iii. Output unit
- iv. Storage unit

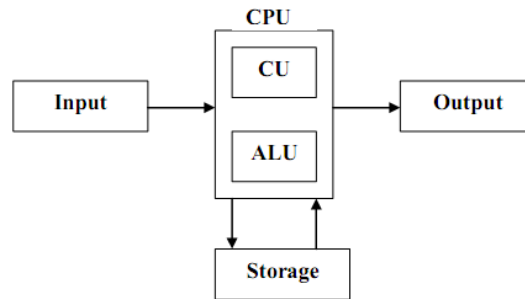

Fig: Computer Unit

#### **i. Input unit**

The unit that allows users to input data into the computer through input devices is known as Input unit. Input devices take input and convert it into binary language that the computer understands. Some of the common input devices are keyboard, mouse, joystick, scanner etc.

#### **ii. Processing Unit**

The unit which processes the data that we supply to the computer is known as processing unit. The **CPU (Central Processing Unit)** is the brain of the computer because it controls everything the computer does. When you enter information using an input device, the CPU processes it and converts into meaningful information. The CPU has three main parts: the **Arithmetic Logic Unit (ALU)**, which handles calculations and logic; the **Control Unit (CU)**, which directs operations; and **Memory**, which store temporary data.

#### **iii. Output Unit**

Devices that display the results of the computer's processing is known as output unit. It converts the binary data coming from the CPU to human understandable form. The common output devices are monitor, printer, plotter, etc.

#### **iv. Storage Unit**

The storage unit is a part of the computer system which is employed to store the information and instructions to be processed. A storage device is an integral part of the computer hardware which stores information/data to process the result of any computational work. Without a storage device, a computer would not be able to run or even boot up.

## 2.2 Input Unit

Some of the input devices are discussed below

### **i. Keyboard**

Keyboard is the most common and commonly used input device. It allow users to input text and commands. It contains different keys for entering letters, numbers, and characters. It is Connected via USB, wireless, or integrated in devices like laptops.

Note: there are 12 function key in keyboard

### **ii. Mouse**

The mouse is a small handheld device commonly used to point and control the cursor on a computer screen. It Includes buttons and scroll wheel for clicking, selecting, and navigating. It is available in wired, wireless, or optical variants. It is used to select, drag, and open files or programs.

### **iii. Scanner**

A scanner is a type of input device that works in the same way as a photocopier. It's used when there's data on paper that needs to be transferred to the computer's hard disk for further processing. It captures images or text from physical documents. It converts paper-based data into digital format for storage.

### **iv. Digital camera**

A digital camera is an input device since it records a video image of the scene in front of it. It can either be incorporated inside the computer (for example, a laptop) or connected via USB. It supports video recording and live streaming applications.

## 2.3 Introduction to processing unit: ALU & Control Unit

The component that handles the majority of processing inside a computer is called the processing unit or processor.

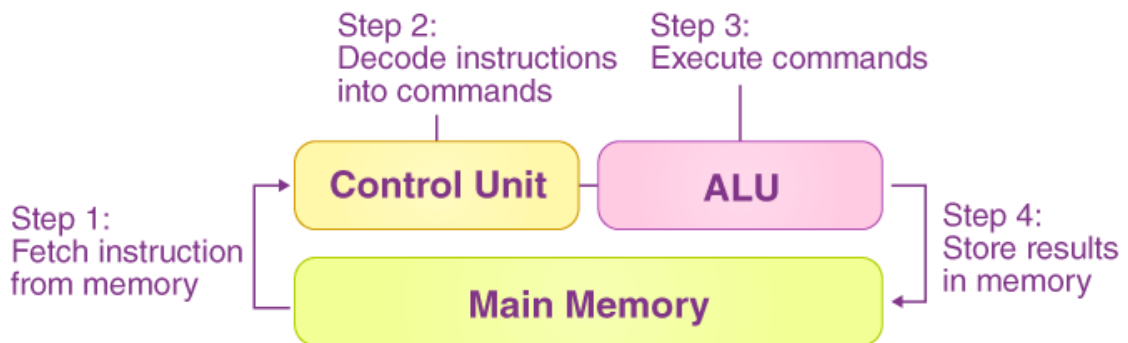

Fig: Main memory, Control unit and ALU

## ALU

As the name implies, the Arithmetic and Logical Unit (or ALU) performs arithmetic and logical functions. The arithmetic operations are addition, subtraction, multiplication division, and comparisons, whereas the logical operations (AND,OR,NOT) mainly include selecting, comparing, and merging the data.

## CU

The control Unit is one of the crucial components of the CPU. It instructs the complete computer system to perform a particular task. It controls and coordinates the functioning of all parts of the computer. It takes instructions from memory and then decodes and executes these instructions.

### 2.4 Introduction to display unit

Computer devices which display information or output are called display units. The most Common type of display unit used nowadays is monitor.

An **image** is a visual representation of an object, person, or scene that we can see on a screen or paper. On a computer monitor, an image is made up of very small dots called **pixels**.

A **pixel (Picture Element)** is the smallest unit of an image displayed on the screen. Each pixel has a different color and brightness. Thousands or millions of pixels together form a complete image.

**Resolution** is the total number of pixels (dots) that make up an image on the screen, usually expressed as width  $\times$  height (for example,  $1920 \times 1080$ ). It determines how clear and detailed the image looks like, the higher the resolution, the sharper the image. Example: A screen with **1920  $\times$  1080 resolution** has **2,073,600 pixels**.

**Layout** means the arrangement of images, text, and graphics on the screen. A good layout makes the display clear and easy to understand. Example: In a monitor, the desktop icons, taskbar, and background are arranged in a layout.

The common types of monitors are described below

- i. CRT (Cathode Ray Tube) Monitors
- ii. LCD (Liquid Crystal Display) Monitors
- iii. LED (Light Emitting Diodes) Monitors

#### **i. CRT (Cathode Ray Tube) Monitors**

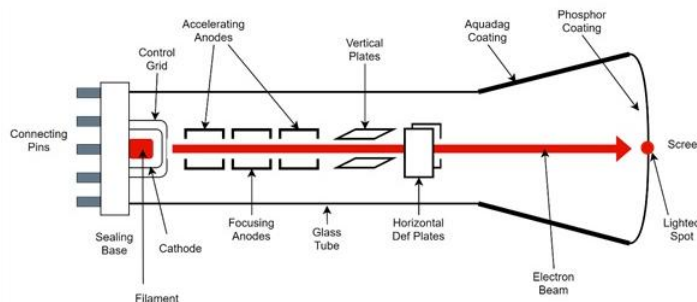

A cathode ray tube (**CRT**) is a specialized vacuum tube which works by using an electron gun (source of electron) to shoot a beam of electron at phosphor coated screen, Which light in response to the electron bombardment.

**Electron gun** generates and focuses a stream of electron into fine beam **control grids** control the intensity of the electron which helps to modify the brightness of the display. The **deflecting system** directs the electron beam precisely to the correct location on the screen for better image. When the electron beam strikes on the screen the phosphor glows and images are created.

## ii. LCD

An LCD (liquid crystal display) monitor is a type computer monitor that uses liquid crystal technology to display images. LCD monitors work by using a backlight to illuminate a layer of liquid crystal cells. These cells are arranged in a grid, and they can be switched on or off to allow light to pass through them. This creates image which is displaced on the screen. The colors of the images are created by filtering the light through red, green and blue color filters.

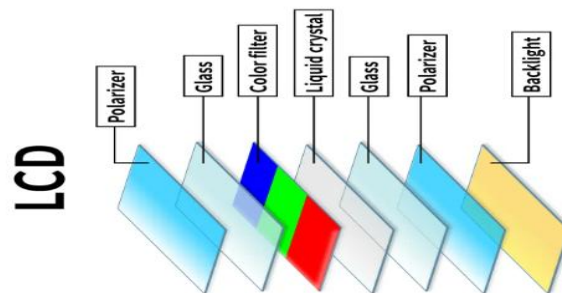

## iii. LED

An LED (Light emitting diodes) monitor is a type of monitor that uses LED technology to provide backlighting for an LCD panel. LED monitors are commonly used in modern computers and have largely replaced other types of monitors including CRT and LCD monitors.

LED monitors work by using an array of light emitting diodes to eliminate the LCD panel, this provides brighter and more uniform backlighting than other types of monitors. LED monitors are more energy efficient than other types of monitors.

Note:

- 2 types of LED monitors are edge lit and full array
- OLED stands for Organic Light-Emitting Diode and it do not use backlight

## Unit 3 Overview On System's Core

### 3.1 Introduction to system BIOS

**BIOS** is the pre-installed software in computer system which is run by microprocessor when computer is turned on. BIOS resides on ROM chip (located in motherboard). It controls the flow of information between OS and IO devices. BIOS is non-volatile in nature. It is independent to OS. It Checks if all the components are in place and working, and then it loads the operating system into the computer's RAM from the hard disk of the system.

#### Functions of BIOS

##### **a) POST (Power On Self Test)**

POST is the process performed by BIOS immediately after the computer system starts to check any hardware-related issues. It performs self-diagnostic tests of computer hardware. It checks memory, processor, and other key hardware to ensure proper functionality of computer system.

##### **b) Boot Device selection**

System BIOS determines the order of boot device in which computer searches for an OS. It typically checks hard drives, CD/DVD, USB until it finds a bootable device.

##### **c) Hardware configuration**

System bias configures the computer's hardware settings based on the values stored in the CMOS (Complementary metal oxide semiconductor) memory. This includes setting for the processor, memory, hard drive, and other hardware components.

##### **d) System security**

System bias provides a security mechanism that protects the computer from unauthorized access. It may require a password to enter the bias setup of utility, or it may have other security features such as Trusted Platform Module TPM Chip.

##### **e) System updates**

System updates fixes bugs and error new features to support new hardware. Updating the bias can be risky operation, however, as a failed update can cause serious problems with the computer's hardware.

##### **f) System recovery**

System bias provides a mechanism for recovering from a failed boot process. It may include a recovery partition on the hard drive or a bootable recovery CD/DVD that can be used to restore the system to a previous state.

## **3.2 Introduction to Motherboard and Form Factors**

The circuit board for a computer system which acts as a central hub for connecting all computer components and peripherals is known as motherboard. It is also known as a logic board or a main board. It is necessary to establish communication between hard disks CPU and GPU for the proper functioning of computer system and hence this task is done by the motherboard

### **Motherboard Form Factor**

The size, configuration, or physical arrangement of computer motherboard is called motherboard form factor. It describes dimension, internal parts of mother board and its configuration.

Different types of computer form factors are described below

#### **i. Standard-ATX**

A Standard-ATX motherboard is one of the most common and widely used motherboard form factors in desktop computers. It is manufactured by Intel in 1995. This type of motherboard has dimensions of 12\*13 inches which allows to have more expansion slots and features than form factors like Micro-ATX or Mini-ITX.

#### **Advantage**

1. It has more expandability (RAM, PCIe slots) than other form factors.
2. It has better cooling and airflow design.
3. The Standard ATX motherboard can easily be upgraded and customized because it has more expandable slots.

#### **Disadvantage**

1. It occupies larger space, so it is not suitable for compact PC
2. It is more expensive than other form factors

#### **ii. Micro -ATX**

Micro-ATX is a smaller version of the standard ATX motherboard, offering a balance between size, cost, and expandability. It is manufactured by Intel in 1997 and has a dimension of 9.6\*9.6 inches. It's popular for building budget-friendly and mid-range desktop computers. Micro-ATX is smaller than the ATX but larger than Mini-ITX.

#### **Advantage**

1. It is cheaper than standard-ATX so cost effective
2. It allows for building compact PCs as it has a smaller size compared to Standard -ATX.

#### **Disadvantage**

1. It has fewer expansion slots.

2. It has a tighter layout which may restrict airflow in small cases.

3. it has fewer features than Standard-ATX

### **iii. Mini-ITX**

Mini-ITX is the standardized small form factor which is developed by VIA in 2001. It has a dimension of 6.7\*6.7 inches. It is popular choice for building small, efficient, and space-saving PC. It is smaller than Micro-ATX and it larger than nano ITX

#### **Advantage**

1. It is a compact size form factor

2. It is more portable than Standard-ATX, Micro-ATX.

#### **Disadvantage**

1. It has less expansion slots (RAM, PCIe slots)

2. It requires careful airflow planning and cable management may be difficult.

### **iv. Nano-ITX**

Nano-ITX is a very small motherboard form factor developed by VIA Technologies in 2003. It has a dimension of 4.7\*4.7 inches, so it is smaller than Standard-ATX, Micro-ATX, Mini-ITX. It is primarily used in embedded systems, IoT devices, digital signage, medical devices, etc.

#### **Advantage**

1. smaller in size so fits in smaller spaces

2. It is very powerful for commercial and industrial use.

#### **Disadvantage**

1. It is not suitable heavy user like game playing, graphic designing

2. It has fewer expansion slots.

### **3.3 Peripheral Component Interconnect (PCI) Local Bus**

PCI is a local bus standard introduced in 1992 for attaching hardware devices like graphics cards, sound cards, network cards, and storage controllers to a motherboard. The function of PCI is to provide a high-speed data pathway between peripherals and the CPU/memory, with standardized slots on the motherboard.

#### **OR**

The PCI local bus is a high-performance bus designed for high-speed data transfer. The PCI bus resides on the system board. This bus is normally used as an interconnect mechanism between highly integrated peripheral components, peripheral add-on boards, and host processor or memory

systems. The host processor, main memory, and the PCI bus itself are connected through a PCI host bridge, as shown in [Figure](#)

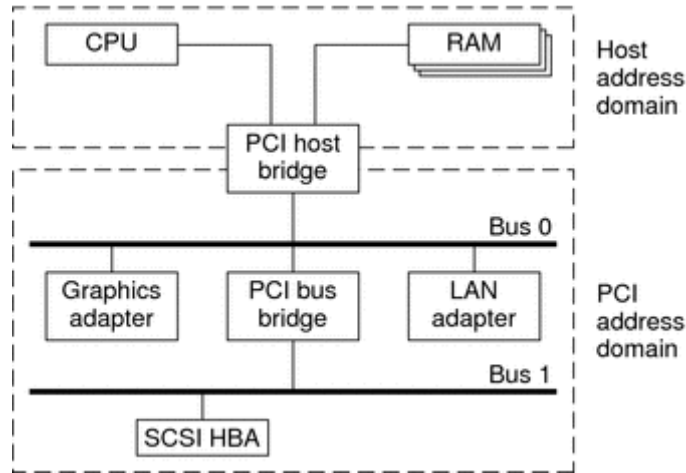

### **3.4 Introduction to Power: the internal power supply, parts of power supply**

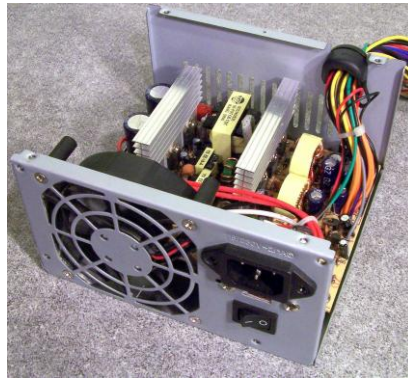

The electric circuit which transforms voltage of alternating current (AC) voltage into direct current (DC) voltage is known as **power supply**. Internal Power Supply unit (PSU) is a hardware component that supplies power to all internal computer parts by converting alternating current (AC, 100–240V) to direct current (DC, typically 3.3V, 5V, 12V). PSU is Mounted inside the computer case, usually at the top-rear or bottom-rear, secured with screws.

#### **The internal component of power supply**

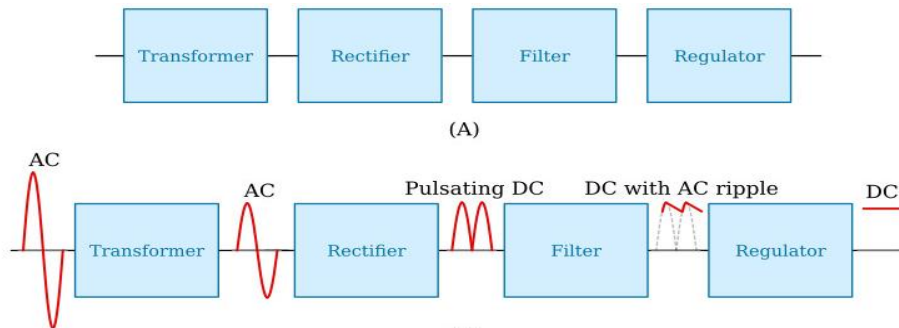

Fig Block diagram of a basic power supply

## **i. Transformer**

A device that transfers electric energy from one alternating-current circuit to one or more other circuits, either increasing (stepping up) or reducing (stepping down) the voltage is known as transformer. It moves electrical energy from primary winding to secondary winding. The transformer's primary winding connects to the ac voltage source, while the secondary one correlates to the load.

## **ii. Rectifier**

A device which is used to convert AC electricity into pulsating DC is known as rectifier. Diode is the basic or fundamental rectifier that is acting as unidirectional device operating in forward direction. The half-wave, the full-wave bridge type, and the full-wave center-tapped are the three basic rectifier circuits that use diodes.

## **iii. Filter**

The filter changes the pulsating DC produced by the rectifier to smooth DC level. It suppresses ripple, that is produced during rectification. High ripples can damage the motherboard and its internal components. There are two main types of filters for power supplies: C-filters and RC-filters. C-filters are the simplest version of filter in power supply.

## **iv. Regulators**

The voltage regulator helps ensure that the DC output voltage is steady regardless of any variation in the input voltage, which enables the load to operate properly. The most common types of regulators are the series voltage regulator and the shunt voltage regulator.

### **3.5 Introduction to hard drives and its construction and operation**

A hard disk drive (HDD) is a fixed storage device inside a computer that uses magnetic technology to retrieve and store digital data for long-term. Unlike RAM, HDDs retain data even when powered off, making them essential for operating systems, applications and files.

#### **Components of HDD**

The different component of hard disk are described below.

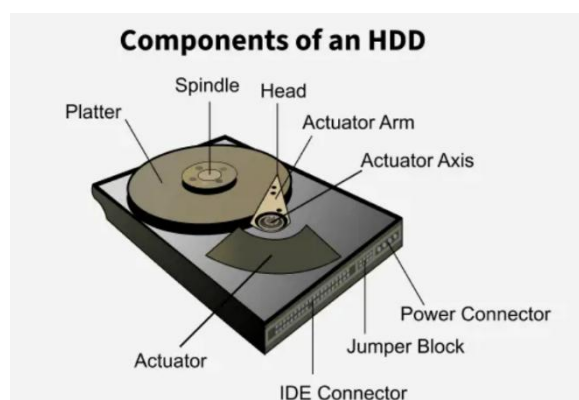

### **a) Platters**

Magnetic platters are disk-like in shape and used to store data. Typically, they are made from glass or aluminium and laid down on a spindle where layers of such disks are kept one after the other.

### **b) Spindle**

The spindle maintains the platters in place and rotates them as required. The Revolution Per Minute (RPM) rating controls how fast data can be written to and read from the hard drive. Most HDDs spin at 5,400 or 7,200 RPM.

### **c) Actuator Arm**

The actuator, also known as the head actuator, is a tiny motor that controls the movement of the read/write head and monitors data transfer between the platters. It is in charge of ensuring that the read/write heads are always in the proper direction.

### **d) Read/write Head**

The read/write arm controls the movement of the read/write heads, that perform the actual reading and writing on the disc platters.

### **e) Other components**

Other components include hard disk's outer shell, which holds other parts of hard disk such as circuit board, ports, power supply ports and so on.

## **Working of Hard Disk Drive**

Most basic hard drives are made up of numerous disk platters, which are circular disks composed of aluminium, glass or ceramic that are arranged around a spindle inside a sealed chamber

- Platters spin at high speeds (typically 5,400 to 15,000 RPM).
- Read/Write heads move to the correct track and position themselves over the sector containing data.
- Magnetic signals are written to or read from the spinning platters.
- The disk controller processes data and transfers it to the computer.

## **3.6 Partitioning, Partition size and drive lettering**

### **Partitioning**

Partitioning in a computer is the process of dividing a single physical storage drive (like an SSD or HDD) into multiple separate, logical sections, which works as an independent drive (e.g., C:, D:) for better organization, running multiple operating systems, or isolating data for security and

backups. These logical drives allow for different file systems, easier reinstallation of OS, and better management of system files and user data.

## **Types of Partition**

### **a) Primary Partition**

The primary partition is the main part of a hard disk. It is used to install the operating system (like Windows). A computer can have up to **four primary partitions**. One primary partition is needed to start (boot) the computer. Primary partitions are directly recognized by the system firmware and are commonly used for operating systems like Windows or Linux.

### **b) Extended Partition**

An extended partition is a special type of partition that is created to overcome the limitation of having only four primary partitions. Instead of storing data directly, it acts as a container that can hold multiple logical partitions. A disk can have only one extended partition, and it cannot be used to install an operating system directly.

### **c) Logical Partition**

A logical partition is created **inside the extended partition**. These partitions are used to store files, folders, and software. We can create many logical partitions, and each one works like a separate drive (for example D:, E:, F:). Logical partitions are usually used to store files, software, or user data, and they appear as separate drives in the operating system, even though they exist within the extended partition.

Note:

#### **What is exactly logical partition?**

Think of the **extended partition as a big box**, and **logical partitions are smaller boxes inside it**. You can create many logical partitions, and each one looks like a separate drive (like D:, E:) on the computer. Logical partitions are mainly used for storing data, not for starting the computer.

## **Windows Partition and Partition size**

A Windows 10/11 partition should ideally be at least **100 GB to 250 GB** for the operating system and essential applications to ensure smooth performance. The Windows partition must be formatted using the NTFS file format.

### **Recommended Partition Sizes**

- **Minimum (Barely Functional):** 64 GB (Too small for long-term use).
- **Comfortable System Drive (Recommended):** 100 GB – 150 GB (Allows room for OS + many applications).
- **Power User/Gamer:** 250 GB – 500 GB (Provides space for large apps and games).

## **Drive lettering**

Drive lettering is a system used by Windows operating systems to identify and organize storage devices using alphabetical letters. Each drive or partition is assigned a unique letter, such as C:, D:, or E:, which acts as an address for accessing files and folders stored on that device. This method helps the computer and the user easily locate different storage areas.

**C:** is typically the primary drive where windows is installed. **A:** and **B:** were reserved for floppy disk so **we do not** see “**A**” and “**B**” drive in windows. Even though floppy disks are no longer used, windows still reserve **A:** and **B:** drive to avoid conflict with older software or system.

## **3.7 Formatting and its type**

Formatting is the process of preparing a storage device such as a hard drive, SSD, or USB so that computer can store and manage data. When you format a drive, the system erases all existing data and creates a new file system so the device can store files properly. This makes the drive clean, organized, and ready to work without errors. Formatting also helps remove viruses, fix corrupted drives, and improve performance. Formatting deletes everything so that users must take a backup before performing it to avoid data loss.

### **Types of Formatting**

- i) Low level formatting
- ii) High level formatting

#### **i) Low level formatting**

Low level formatting is a type of physical formatting. It is formatting type which is performed at the hardware level. In this format, physical structure of storage device is defined where data will be stored. Usually low level formatting is done by the manufacturer. All the data will be erased and cannot be recovered once low level formatting is done.

#### **ii) High level formatting**

High level formatting is the process of creating a file system and directory structure on disk, allowing it to be recognized and used by an operating system. It is performed by the user or Operating System. In high level formatting, it creates or setups of file systems like FAT32, NTFS, etc. This type of formatting prepares the disk for actual data storage and file management. High level formatting can be done using OS tools like Disk Management in windows or disk utility in MacOS.

## **Unit 4 Troubleshooting Techniques**

### **4.1 General troubleshooting techniques**

The systematic approach for identifying and solving a problem in system such as computer, network, or software applications is called troubleshooting. The goal of troubleshooting is to find out why system is not working properly as expected and explain how to resolve the problem.

Some general troubleshooting techniques are described below

- a. Free up RAM by closing other open programs
- b. Restart the software
- c. Shut down and restart the computer
- d. Use the internet to find help
- e. Undo any recent hardware or software changes
- f. Uninstall the software, then reinstall it
- g. Look for software patches
- h. Scan for Virus and malware

#### **a. Free up RAM by closing other open programs**

RAM (Random Access Memory) is crucial for the smooth operation of software. Closing unnecessary programs frees up memory, allowing the system to allocate more resources to the software you're troubleshooting, potentially resolving performance issues.

#### **b. Restart the software**

Sometimes, software can encounter glitches or become unresponsive due to temporary errors. Restarting the software clears its current state and reloads it, often resolving minor issues.

#### **c. Shut down and restart the computer**

Restarting the entire system can resolve a wide range of issues. It clears temporary files, resets system settings, and refreshes system processes, potentially resolving software or hardware-related problems.

#### **d. Use the internet to find help**

Online resources such as forums, knowledge bases, and support websites can provide valuable insights and solutions for troubleshooting specific issues. Users can search for error messages, symptoms, or descriptions of the problem to find relevant solutions

#### **e. Undo any recent hardware or software changes**

If the problem occurred shortly after installing new hardware or software, reverting those changes can help identify the root cause. This could involve removing recently installed programs, disconnecting newly added hardware, or restoring system settings to a previous state.

#### **f. Uninstall the software, then reinstall it**

Reinstalling the software can fix corrupted files, configuration errors, or incomplete installations. It ensures a clean installation of the software, eliminating potential issues that may have occurred during the initial installation.

#### **g. Look for software patches**

Software developers frequently release updates and patches to address bugs, security vulnerabilities, and performance issues. Installing the latest patches for the software can resolve known issues and improve its stability and functionality.

#### **h. Scan for Virus and malware**

Software can freeze, crash or stop functioning properly due to viruses and malware. Viruses make our computer slow and make system malfunction. We need to scan our computer regularly so that it can detect and remove virus and malware from our computer system.

### **4.2 Steps of troubleshooting**

- i. Gather information
- ii. Describe the problem
- iii. Determine the most probable cause
- iv. Create a plan of action and test a solution
- v. Implement the solution
- vi. Analyze the results
- vii. Document the process

#### **i. Gather information**

The first step in troubleshooting is to collect all necessary information related to issues or problems in computer systems. This may include error messages, symptoms, recent changes to the system, and any other details. The more information you have, the easier it will be to diagnose and resolve the issue.

## **ii. Describe the problem**

Once information is collected, the next step is to clearly define the problem. This involves identifying what is not working as expected and how is affecting the system or user. A clear problem statement helps in narrowing down the possible cause and avoids the confusion during troubleshooting process.

## **iii. Determine the most probable cause**

Based on the gathered information and problem description, identify the most likely cause of the issue. Consider factors such as recent changes, known issues with similar systems, and common causes for the symptoms observed.

## **iv. Create a plan of action and test a solution**

Once the probable cause has been identified, proceed to implement a solution. This may involve applying fixes, adjusting settings, reinstalling software, or performing other troubleshooting steps specific to the problem at hand.

## **v. Implement the solution**

Once the probable cause has been identified, proceed to implement a solution. This may involve applying fixes, adjusting settings, reinstalling software, or performing other troubleshooting steps specific to the problem at hand.

## **vi. Analyze the results**

After implementing the solution, analyze the results to see whether the problem has been resolved or not. Check the system for any recurrence of the issue and verify that the desired outcome has been achieved.

## **vii. Document the process**

Documenting the troubleshooting process is essential for future reference and knowledge sharing. Record the steps taken, the solution implemented, any challenges encountered, and the final outcome. This documentation can serve as a reference for similar issues in the future and help others facing similar problems.

## **4.3 Troubleshooting boot problems**

**A boot problem** in computer systems is any problem or issues that prevents the computer from successfully start up and loading operating systems.

General troubleshooting technique for boot problems are listed below

- a) Try to start windows in safe mode
- b) Check your battery whether it is installed correctly or not
- c) Unplug all the connected USB devices from your system
- d) Check if your BIOS/UEFI settings are working or not

- e) Try scanning malware in your computer system
- f) try command prompt to solve boot issues
- g) Use system restore or startup Repair

#### **4.4 Troubleshooting boot time error messages**

A **boot time error** message is the message displayed on the screen when computer system encounters a problem during startup before the operating system loads.

The message can appear as text on the screen or as beep sound codes preventing the system start up correctly. “No Bootable Device Found”, “Bootmgr is missing”, are some of the boot time error messages.

The steps for troubleshooting boot time error messages are as follows

##### **a) Look for specific error message**

When a system fails to boot, it often displays an error message like “operating system not found”, “No bootable device found”. Carefully reading and analyzing the error displayed helps to understand the root cause.

##### **b) Perform general EFI troubleshooting task.**

EFI (Extensible Firmware Interface) Troubleshooting can resolve many boot issues. Some of the EFI troubleshooting steps are

- Restart Your computer and enter the EFI/UEFI settings (Usually by pressing a key like F2, F12 Del or Esc during start up)
- Check for boot order
- In some cases, Secure Boot may prevent the system from booting properly. So try disabling it temporarily.
- If you are using older operating systems, enable “Legacy Boot”.
- Update EFI/UEFI Firmware

##### **c) Remove non-system disk from the computer**

Sometimes, the system may try to boot from an external USB drive or CD/DVD that doesn't have operating system. Removing such non bootable devices ensure the systems attempts to boot from the correct internal drive

##### **d) Restore BIOS default settings**

Incorrect BIOS settings may prevent the system from booting properly. Restoring BIOS to its default setting can often fix issues during boot time.

#### **e) Perform memory**

Faulty RAM and storage devices can cause boot failures and system crashes. Run a memory test such as “Windows Memory Diagnostic” so that it helps to replace faulty modules or components if needed.

#### **f) Perform a hard drive test**

Boot time error messages may occur if there are any faults or problems in hard disk. So, in order to prevent Boot time error, make sure that your hard disk is working properly.

#### **g) Reinstall Windows operating system**

If none of the above steps solve the problem, reinstalling the Windows operating system may be the last option. This involves formatting, and installing a fresh copy of Windows operating system

### **4.5 Troubleshooting system slow down**

Steps for solving the system down are as follows

- a. Remove unnecessary files and photos
- b. Delete your recycle bin and clear temporary files
- c. Add more RAM
- d. Install anti-virus software
- e. Disable start up programs
- f. Remove unused software
- g. Choose substance over style
- h. Upgrade your PC’s storage device
- i. Don’t sleep on the job

#### **a. Remove unnecessary files and photos**

Regularly delete files and photos that you no longer need. Use disk cleanup tools like Windows Disk Cleanup or third-party software like CCleaner to help identify and remove junk files.

#### **b. Delete your recycle bin and clear temporary files**

Empty the Recycle Bin to permanently remove deleted files. Clear temporary files by accessing the Windows Disk Cleanup tool or manually deleting the contents of the Temp folder (‘C:\Windows\Temp’).

### **c. Add more RAM**

Upgrading your RAM can significantly improve performance, especially if your system often runs out of memory. Check your computer's specifications to see the maximum RAM capacity and compatible types.

### **d. Install anti-virus software**

Install reliable anti-virus software to protect against malware, which can slow down your system. Schedule regular scans and keep the software updated.

### **e. Disable start up programs**

Disable unnecessary programs that start automatically with your computer to speed up the boot process. Use Task Manager in Windows (Ctrl + Shift + Esc) and navigate to the Startup tab to manage these programs.

### **f. Remove unused software**

Uninstalling pre-installed software, you no longer use can significantly speed up your computer. Go to Control Panel > Programs and Features to uninstall unnecessary programs.

### **g. Choose substance over style**

Disable unnecessary visual effects and animations to improve performance and speed up you computer. Go to System Properties > Advanced > Performance Settings and choose "Adjust for best performance" or customize which effects to disable.

### **h. Upgrade your computer's storage device**

Consider upgrading to a Solid-State Drive (SSD) if you're currently using a Hard Disk Drive (HDD). SSDs offer faster read/write speeds, which can significantly enhance overall performance. If you already have an SSD, ensure it has enough free space and consider upgrading to a larger capacity if necessary.

### **i. Don't sleep on the job**

Avoid leaving your computer in sleep mode for extended periods. Instead, perform regular restarts to clear out memory and ensure smooth operation. Restarting can help in applying updates and clearing out temporary glitches.

## **4.6 Troubleshooting specific components**

When problems affect a specific hardware component or peripheral, targeted troubleshooting is necessary. Here are some common components and how to address issues

### **Troubleshooting a Graphics Card**

If you notice graphical problems such as screen flickering, artifacts, or no display, follow following troubleshooting techniques:

- ❖ Ensure the graphics card is properly seated in the PCIe slot.

- ❖ Verify that all power connectors to the graphics card are securely connected.
- ❖ Update or reinstall the graphics drivers.
- ❖ Monitor the GPU temperature using tools like MSI Afterburner or GPU-Z to check for overheating

### **Troubleshooting RAM (Memory)**

If your computer is experiencing system crashes, Blue Screen of Death (BSOD), or frequent application errors, the problem may be related to RAM.

Troubleshooting step:

- ❖ Remove and reinstall the RAM modules to make sure they are properly inserted into the memory slots.
- ❖ Use a memory testing tool such as Windows Memory Diagnostic to detect possible RAM problems.
- ❖ Test each RAM module separately to identify any defective memory stick.
- ❖ Verify that the RAM is compatible with your motherboard and properly configured in the BIOS/UEFI settings.

### **Troubleshooting Hard Drive/SSD:**

If you're experiencing slow file access, data corruption, or system freezes:

- ❖ Check disk health using SMART monitoring tools (e.g., CrystalDiskInfo for Windows).
- ❖ Use a disk scanning and repair tool such as “**chkdsk**” on Windows or “**fsck**” on Linux/macOS to check and fix disk errors.
- ❖ Make sure the hard drive or SSD is properly and securely connected to the system.
- ❖ Regularly back up important data to avoid permanent data loss in case of drive failure.

### **Troubleshooting Hard Drive/SSD:**

If you're experiencing slow file access, data corruption, or system freezes:

- ❖ Check disk health using SMART monitoring tools (e.g., CrystalDiskInfo for Windows).
- ❖ Use a disk scanning and repair tool such as “**chkdsk**” on Windows or “**fsck**” on Linux/macOS to check and fix disk errors.
- ❖ Make sure the hard drive or SSD is properly and securely connected to the system.
- ❖ Regularly back up important data to avoid permanent data loss in case of drive failure.

### **Troubleshooting CPU**

If your computer is overheating, experiencing system crashes, or running slow:

- ❖ Monitor CPU temperature using software like Core Temp.
- ❖ Clean the CPU heatsink and fan to remove dust and improve cooling.
- ❖ Ensure the CPU cooler is seated properly.
- ❖ Check for thermal paste application and reapply if necessary.

## **Troubleshooting Power Supply Unit (PSU)**

If your computer randomly shuts down or restarts:

- ❖ Test the PSU with a PSU tester or replace it with a known working one.
- ❖ Ensure all power connectors are securely connected to the motherboard, GPU, and other components.

## **Troubleshooting Peripherals (e.g., Keyboard, Mouse, USB devices)**

If your peripherals are not working correctly or are not recognized:

- ❖ Try connecting them to different USB ports.
- ❖ Test the peripherals on another computer to rule out hardware issues.
- ❖ Update or reinstall drivers for the specific device if applicable

## **Troubleshooting Motherboard Issues**

If you suspect motherboard-related problems, such as no power or erratic behavior:

- ❖ Inspect for visual damage or burnt components on the motherboard.
- ❖ Check for loose or damaged cables and connections.
- ❖ Clear CMOS settings by removing the CMOS battery or using a jumper, if necessary.
- ❖ Consult your motherboard's manual for specific troubleshooting steps.

## **Troubleshooting Network Components (e.g., Ethernet/Wi-Fi)**

If you are facing network connectivity problems, try the following steps:

- ❖ Restart your router and modem to refresh the network connection.
- ❖ Inspect Ethernet cables to ensure they are not loose or damaged.
- ❖ Update or reinstall the network drivers to fix possible software issues.
- ❖ Use network troubleshooting commands such as “**ipconfig**” on Windows or “**ifconfig**” on Linux to diagnose connection problems.

## Chapter 5 Repair and maintenance

### 5.1 Preventive maintenance of the system

The regular and systematic inspection, cleaning and replacement of damaged parts, materials, and system is called **preventive maintenance**. Regular checkup and inspection must be performed to ensure system works properly. Effective preventive maintenance reduces failures of parts material, saves money, keeping hardware and software in good working condition.

some of the preventive maintenance measures are as follows:

1. Clean the computer system.
2. Download the latest drivers for the hardware.
3. download the latest update for the computer system.
4. Check whether you have the latest version of anti-virus or not.
5. Run disk software such as disk defrag and Scandisk on the hard drive.
6. Remove unused programs and files from your computer.
7. Don't keep your computer in sleep mode, shut down your computer after the use.

### 5.2 Fixing wireless network connection issues

Some of the steps for fixing network problems are described below:

1. Check if the Wi-fi is turned on or not on the computer system.
2. Change frequency band (2.4 GHz or 5 GHz) of the network device.
3. Restart the device and router.
4. Update or reinstall network drivers.
5. Make sure the physical wi-fi switch or router is turned on.
6. Run the network troubleshooter on the computer.

### 5.3 Power supply and power protection

**A Power Supply Unit** also known as **PSU** is an essential computer hardware component that converts alternating current (AC) into direct current (DC) and then supplies voltage to every component connected to the system.

Power protection in computer system is very important. Power protection can save our money, time, and even a physical damage to our hardware of computer systems. If the voltage provided by power source is incorrect or fluctuated then it may create serious problems such as System instability, overheating, random shutdowns.

There are several power protection devices that protect our computer and hardware system. Some of them are explained below:

### **i) Surge Suppressor (Protectors)**

**Surge Suppressor** is the device that protects computers and other electronic equipment from sudden increases in voltage, which is known as power surges. Computers are very sensitive to changes in electricity, and even a small surge can damage parts like the motherboard, hard disk, or power supply. A surge protector works by blocking the extra voltage away from the computer, allowing only safe levels of power to pass through it. They are often used in the form of multi-socket power strips and can connect several devices at once. Surge suppressor keeps the system safe during voltage spikes caused by lightning, faulty wiring, or sudden switching of heavy electrical devices. For better protection, surge protectors should be used together with UPS systems.

### **ii) Phone line surge protector**

A **phone line surge protector** is a special type of surge protection device designed to safeguard telephones, modems, fax machines, and networking equipment that are connected through telephone lines. Just like power lines, phone lines can also carry dangerous voltage surges, especially during lightning strikes or faults in the telephone network. These sudden surges can travel through the phone cable and damage sensitive components inside a computer's modem, router, or other communication devices. A phone-line surge protector works by filtering or diverting the excess voltage to the ground, allowing only safe signals to pass through it.

### **iii) Line conditioner**

A **line conditioner** is a power protection device that improves the quality of electricity supplied to a computer or other sensitive electronic equipment. Unlike basic surge protectors that only guard against sudden voltage spikes (increase), a line conditioner regulates the voltage to keep it within a safe and stable range. It protects against overvoltage, undervoltage, and electrical noise that may harm computer components or cause malfunction. Line conditioners are especially useful in areas where the power supply is unstable or where heavy electrical equipment causes fluctuations. They are often used in offices, labs, and data centers where reliable power is critical.

### **iv) Standby power supply (SPS)**

A **standby power supply (SPS)** is a device that provides temporary backup electricity to a computer when the main power supply fails. Under normal conditions, the SPS allows the computer to run directly on mains power while keeping its internal battery charged. When a power outage or voltage drop occurs, the SPS automatically switches to battery power to keep the system running for a short time, usually a few minutes. This gives the user enough time to save work and shut down the computer safely. While SPS units are generally less expensive and simpler than online UPS systems, they provide basic protection against sudden power loss.

#### v) **Uninterruptible power supply (UPS)**

An **Uninterruptible Power Supply (UPS)** is a power protection device that provides continuous and stable electricity to a computer or other electronic equipment, even when the main power supply fails. Unlike a simple surge protector, a UPS contains a battery that instantly takes over when a power outage, voltage drop, or fluctuation occurs. This prevents sudden shutdowns, which can cause data loss, file corruption, or damage to the operating system. A UPS also protects against power surges, spikes, and noise in the electrical line, ensuring that only clean and safe power reaches the computer.

### **5.4 Failure or improper operation of video card**

Hardware component that is responsible for rendering images, videos, and animations for display on the monitor is known as video card or graphics card. When a graphics card starts to fail or does not work properly, it directly affects the display and overall performance of the computer.

#### **How do you recognize graphics card failure??**

Some ways to recognize graphics card failure are listed below

1. Programs may frequently stutter and slow down.
2. System crashed while executing intensive graphics tasks such as video editing.
3. Unexpected graphical bugs that didn't exist before.
4. Overheating and Loud Fan Noise in the system while performing the task.

#### **Causes of video card failure**

There may be many reasons that makes the failure of proper functioning of video cards. Some of the reasons that makes the video card failure are listed below

1. Dust buildup on the video card.
2. Low or defective RAM.
3. Incorrect installation of graphics cards on the mother board.
4. An inoperative power supply unit.
5. Poor ventilated space in the system.

#### **How to fix video card problems??**

If the computer issues still exist after physical inspection and repairment, carry out following troubleshooting techniques:

1. Check the Connections
2. Update or Reinstall Drivers
3. Check the Power Supply
4. Clean and Cool the Card
5. Test with Another Card or Monitor

6. Check for Software Issues
7. Replace the Card (If Necessary)

### **1. Check the Connections**

Sometimes the problem is as simple as a loose connection. Make sure the monitor cable (HDMI, VGA, or DisplayPort) is connected tightly. If the card is inserted in the motherboard slot, remove it carefully and put it back firmly. This ensures proper connection.

### **2. Update or Reinstall Drivers**

Drivers are special programs that allow the operating system to communicate with the video card. If the driver is outdated or corrupted, the card may not work correctly. Download the latest driver from the manufacturer's website (NVIDIA, AMD, or Intel). If the problem continues, uninstall and reinstall the driver.

### **3. Check the Power Supply**

The graphics card needs enough power to function. If the power supply (PSU) is weak or its cable is not connected, the card will not work. You should confirm that the PSU meets the graphics card requirements and that all power connectors are properly attached.

### **4. Clean and Cool the Card**

Dust and heat are common reasons for video card failure. Overheating happens when the fan or heatsink is blocked by dust. You should carefully clean the GPU fan and heatsink using compressed air and make sure the computer case has good airflow.

### **5. Test with Another Card or Monitor**

To know if the problem is really in the video card or somewhere else, you can test by using another working graphics card in the system.

- ❖ If the computer works fine, the old card is faulty.
- ❖ If the problem remains, then the issue is with the system (like the motherboard, RAM, or drivers).

### **6. Check for Software Issues**

Sometimes the problem is not hardware but software. You should scan the computer for viruses, disable any unwanted graphics related settings, and check if the issue started after a new update, if yes rolling back recent updates may solve the problem.

### **7. Replace the Card (If Necessary)**

If none of the above steps work, it means the graphics card is physically damaged. In this case, you should replace the card with a new one.

## **5.5 Image Quality problems in monitors (Resolution, Layout)**

An **image** is a visual representation of an object, person, or scene that we can see on a screen or paper. On a computer monitor, an image is made up of very small dots called **pixels**.

A **pixel (Picture Element)** is the smallest unit of an image displayed on the screen. Each pixel has a different color and brightness. Thousands or millions of pixels together form a complete image.

**Resolution** is the total number of pixels (dots) that make up an image on the screen, usually expressed as width × height (for example, 1920 × 1080). It determines how clear and detailed the image looks like, the higher the resolution, the sharper the image. Example: A screen with **1920 × 1080 resolution** has **2,073,600 pixels**.

**Layout** means the arrangement of images, text, and graphics on the screen. A good layout makes the display clear and easy to understand. Example: In a monitor, the desktop icons, taskbar, and background are arranged in a layout.

**Images** are formed by combining **millions of pixels**. The monitor lights up each pixel with different brightness and color. When seen together, these pixels create a clear picture for our eyes.

**Image quality** can be termed as how clear, sharp, and realistic an image looks on the screen. It depends on factors like: Resolution, color depth, refresh rate, layout and scaling

### **Refresh Rate:**

The refresh rate is the number of times per second a monitor updates the image on the screen. It is measured in **Hertz (Hz)**. Example: A **60 Hz** screen refreshes 60 times per second, while a **120 Hz** screen refreshes 120 times per second. A **higher refresh rate makes** motion look smoother and reduces flickering.

**Some of the image quality problems in monitors are described below:**

- 1. Low Resolution** – Image looks blurred or unclear because of fewer pixels.
- 2. Improper Layout/Scaling** – Text and icons appear too big or too small.
- 3. Dead Pixels** – Small spots on the screen that do not show color.
- 4. Flickering** – Screen shakes due to low refresh rate.
- 5. Color Distortion** – Colors look strange or different from real.
- 6. Ghosting/Shadowing** – A faint copy of the image appears behind moving objects.
- 7. Over-brightness or Dim Display** – Image looks too bright or too dark.

### **Solutions to Image Quality Problems**

Set the monitor to its **native resolution** (best pixel setting).

1. Adjust **layout and scaling** in display settings for proper size of text/icons.

2. Use a **higher refresh rate** (e.g., 60Hz, 120Hz) to reduce flickering.
3. Keep monitor drivers and graphics drivers updated.
4. Calibrate brightness, contrast, and color settings.
5. Replace or repair monitor if there are many **dead pixels**.
6. Ensure proper connection of cables (HDMI, VGA, DisplayPort).
7. Avoid strong magnets or electronic interference near monitors.

### **5.6 Input and output device connection issues**

A computer system depends on **input devices** to enter data and **output devices** to display results. If these devices are not connected or configured properly, the computer cannot work effectively. Knowing the problems and their solutions helps us to use the computer smoothly.

#### **Solutions to Input and Output Device Connection Issues:**

1. Check and reconnect all **cables and ports** properly.
2. Make sure devices are powered **ON**.
3. Install or update the correct **drivers**.
4. Check **settings** (volume, display, printer setup, microphone permissions).
5. Restart the computer after reconnecting devices.
6. Replace damaged cables or faulty devices.

### **5.7 Processor Power and Voltage level**

The **processor (CPU)** is the “brain” of a computer system. It performs all calculations and instructions. To function properly, the CPU needs a **stable power supply** and the correct **voltage level**. If the voltage is too high or too low, it may damage the processor or cause the system to crash.

**Processing power:** The ability of a computer’s processor (CPU) to complete tasks and calculations in a given time is called processing power.

The power supply voltage provided to the CPU, GPU, or any device containing processor core is known as **CPU core voltage**. The sum of this voltage and current it draws determines how much power a CPU requires to operate. A CPU normally operates in between 0.9 to 1.3 volts.

#### **5.8 Processor cooling Method:**

The processor (CPU) performs millions of calculations per second. While doing this, it consumes power and generates heat. Excessive heat can:

- Reduce CPU performance
- Cause system crashes

- Damage the processor permanently

To prevent above problems, different cooling methods are used to maintain a safe temperature. Some of them are described below:

1. heat sink
2. fan
3. thermal paste
4. liquid cooling
5. phase-change cooling
6. heat pipe
7. passive

**(Describe above points from your book)**

### **5.9 Cooling and ventilation**

In computing the term “cooling” often refers to the dissipation of significant heat when a computer system is operating.

#### **Why is ventilation required for computers?**

Ventilation is necessary in computers because all the internal components such as the CPU, GPU, power supply, and hard drives generate heat while operating. If this heat is not removed, the internal temperature of the system will keep rising, which can cause many problems like **slow performance, frequent crashes, data loss, and even permanent damage to hardware**. Proper ventilation allows cool air to enter the computer case and hot air to exit, keeping the components at a safe temperature.

Good ventilation helps:

- **Prevent Overheating:** Keeps components from getting too hot.
- **Improve Performance:** A cooler computer runs faster and more reliably.
- **Extend Hardware Life:** Reduces wear and tear on sensitive parts.
- **Reduce Fan Noise:** Fans don't need to spin at full speed all the time.

#### **Methods for cooling in pc**

##### **1. Keep System Away from Vents and Windows**

Place the computer away from heat sources such as room heaters, windows with direct sunlight, or air vents that blow hot air. Heat from outside can raise the temperature inside the case, making the cooling system work harder.

## **2. Give System Some Breathing Room**

Make sure there is enough space around the computer case, especially at the back where hot air is exhausted. If the computer is placed inside a closed space or against a wall, the airflow gets blocked, and heat stays trapped. Leave at least a few inches of space so air can circulate freely.

## **3. Close System's Case**

Many people think leaving the case open keeps the system cooler, but this actually disrupts proper airflow. A closed case allows cool air to flow in a controlled path that comes in from intake fans and hot air is pushed out by exhaust fans.

## **4. Clean Fans**

Dust is one of the biggest enemies of computer cooling. Over time, dust collects on fans, heatsinks, and vents, reducing airflow and making fans work harder. Regularly cleaning fans with compressed air or a soft brush helps maintain proper airflow and cooling efficiency.

## **5. Upgrade CPU Fan**

The CPU generates the most heat in a computer. If the cooling fan is not sufficient, upgrading to a better CPU cooler (with a bigger heatsink and faster fan) helps reduce the temperature. This is especially important for gaming PCs or systems running heavy workloads.

## **6. Add a Case Fan**

Most computer cases allow installing additional fans. Adding intake fans at the front or bottom and exhaust fans at the back or top of the case improves airflow. This helps move more cool air through the case and push hot air out faster.

## **7. Add a Memory Cooling Fan**

RAM modules can also get hot when the computer is under heavy use. Installing a small fan or a memory cooler directly above the RAM helps prevent overheating and increases stability, especially when doing tasks like gaming or video editing.

## **8. Get a Water Cooling Kit**

Water cooling is a more advanced method where liquid is used to absorb heat from components like the CPU or GPU and transfer it to a radiator, which then cools the liquid with fans. Water cooling is very efficient and keeps the system much cooler, but it is more expensive and requires careful installation.

## **5.10 Virus Background**

### **Virus background**

A **computer virus** is a type of malicious software program designed to disrupt normal computer operations, steal information, damage files, or spread to other computers.

In the 1990s and early 2000s, viruses spread quickly through the internet and email, with famous examples like Melissa and ILOVEYOU. Today, we find wider category of malware, which also includes worms, trojans, ransomware, and spyware. The main characteristics of a computer virus are that it can replicate itself, attach to a host program, spread through USB drives, networks, or the internet, and cause harm by deleting data, stealing information, or slowing down the system.

#### **1. File Virus**

A file virus is one of the most common types of computer viruses. It attaches itself to executable files such as **.exe**. When the infected file is opened or executed, the virus activates and can spread to other files on the computer. Some file viruses may corrupt or delete files, while others simply spread silently.

#### **2. Boot Sector Virus**

Boot sector viruses infect the boot sector or Master Boot Record (MBR) of storage devices like hard disks or USB drives. Since the boot sector is read first when the computer starts, this virus loads into memory before the operating system, making it dangerous and harder to remove. It can make a computer unbootable or cause system crashes.

#### **3. Macro Virus**

Macro viruses are written in macro programming languages such as those used by Microsoft Word or Excel. They infect document files and templates. When a user opens an infected document, the virus runs automatically and can spread to other documents. These viruses are dangerous because they spread quickly through email attachments and shared files.

#### **4. Source Code Virus**

Source code viruses are designed to modify the source code of programs. When the infected source code is compiled, the virus becomes part of the program and spreads to other programs or systems where the code is used. This type of virus is common in development environments and can be very difficult to detect.

#### **5. Encrypted Virus**

Encrypted viruses use encryption techniques to hide their malicious code from antivirus programs. They encrypt themselves with a different key every time they infect a new file, so their signature keeps changing. Antivirus software must use special decryption techniques to detect and remove them.

## **6. Stealth Virus**

Stealth viruses are designed to hide their presence by intercepting system requests and showing false information to the user or antivirus programs. For example, they can make infected files appear clean when scanned. This makes them more difficult to detect and remove.

## **7. Tunneling Virus**

A tunneling virus attempts to bypass the normal functioning of antivirus programs by attacking them directly or by infecting at a lower level of the operating system. It can trick antivirus software into thinking everything is fine while continuing its malicious activities in the background.

## **8. Multipartite Virus**

Multipartite viruses are hybrid viruses that can infect in multiple ways. They can attack both the boot sector and files at the same time, making them very hard to clean. Even if one part of the virus is removed, it can still reinfect the computer from another source.

## **9. Browser Hijacker**

A browser hijacker is a type of virus or malware that modifies the settings of a web browser without the user's permission. It can change the default homepage, search engine, or redirect users to unwanted websites. It is often used for advertising, data theft, or phishing attacks.

## **10. Resident Virus**

Resident viruses load themselves into the computer's memory and remain active even after the original infected program is closed. Since they run in the background, they can infect other files, programs, and even removable media without user action.

### **5.11 Virus detection, protection, and prevention**

Virus detection and prevention steps

1. Run a virus check before we try to open any disk drive, SSD we receive from someone.
2. Never open any files that are attached to email from unknown sources.
3. Even if it seems to be from a close friend or someone, never open attachment to emails until you verify
4. Delete spam and chain emails.
5. Never download files from unknown sources.
6. Before downloading files make sure that file is authentic and scan the download site by using antivirus software.
7. Every week, update antivirus and computer system
8. Make regular backup of our files because we can replace file after even it is affected by virus.

## **Virus Protection and Prevention Techniques**

1. Protect ourselves and our devices
2. Keep device secure
3. Keep system up to date
4. Use antivirus software
5. Antispyware Software
6. Firewall protection
7. Use strong protection
8. Choose strong passwords
9. Use stronger Authentication
10. Protect Private Information
11. Be careful what we click
12. Shop safely
13. Be careful what
14. Responding to Data Breaches
15. Parents, Take control

## Chapter 6 Backup and Recovery

### 6.1 Introduction to backup and recovery

**Backup and Recovery** are important processes in computer systems to protect and restore data. Data may be corrupted or lost due to system error and failure, so data recovery is a very important for an organization.

**Backup** is the process of making a copy of important data and files and kept in different locations so that it can be used to restore the original during data loss event.

**Recovery** is the process of restoring the data that has been lost, mistakenly deleted, corrupted using different backup methods.

### 6.2 Backup methods, devices, and media

Different types of backup methods are discussed below:

- i. Full backup
- ii. Incremental backup
- iii. Differential backup

#### **i. Full backup**

A **Full Backup** is a method where all the data on a computer or device is copied and stored in a backup location. This includes every file, folder, and setting, whether it has **changed or not**. It takes more time and uses more storage space, but it is the easiest to restore because **everything is in one place**. Full backups are often done weekly or monthly, and they form the base for other types of backups.

#### **ii. Incremental backup**

An **Incremental Backup** only saves the data that has changed or been added since the last backup. This method is much faster and uses less space compared to full backup. However, during recovery, all incremental backups must be restored in order, which can take more time. It is often used daily to keep backups updated with minimum storage.

#### **iii. Differential backup**

A **Differential Backup** is a type of backup that saves all the files that have been changed or added **since the last full backup**. It does not back up everything, only changes made after the last full backup. The size of the differential backup **keeps increasing each day** until a new full backup is done.

Let us take the scenario below:

Sunday: You take a **full backup** (backs up everything).

Monday: You change 2 files → **Monday's differential** backs up those 2 files.

Tuesday: You change 3 more files → **Tuesday's differential** backs up all **5 changed files** (Monday's + Tuesday's changes).

Wednesday: You change 1 more file → **Wednesday's differential** backs up **all 6 changed files** (since Sunday).

## **Types of Storage Devices**

- i. External Hard Disk
- ii. Solid-state drives (SSD)
- iii. USB flash drives
- iv. CD technology
- v. DVD technology
- vi. Online storage

### **i. External Hard Disk**

An external hard disk is a portable storage device that connects to a computer using a USB or Thunderbolt cable. It is commonly used for backing up important data, transferring large files, or expanding the storage capacity of a computer or laptop. These hard disks come in various sizes, ranging from 500GB to several terabytes (TB), and are easy to carry around. Since they are external, they can be used with multiple devices and are great for keeping personal or work data safe.

### **ii. Solid-state drives (SSD) and USB flash drives**

A Solid-State Drive (SSD) is a modern storage device that uses flash memory to store data, instead of spinning disks like an HDD. SSDs are much faster, lighter, and more durable because they have no moving parts. They allow computers to boot up quickly and open files or applications in seconds. Although SSDs are more expensive than HDDs, they are becoming more common in laptops and high-performance computers due to their speed and reliability.

### **iii. USB flash drives**

A USB flash drive, also known as a pen drive, is a small and portable storage device that plugs into a computer's USB port. It is widely used for transferring files between devices, storing presentations, or carrying important documents. Flash drives come in a range of storage sizes, from 4GB to 256GB or more. They are lightweight, easy to use, and require no power source other than the device they are connected to.

### **iv. CD technology**

CD stands for Compact Disc. It is a type of optical storage device that uses **laser technology** to read and write data. A standard CD can store up to **700 MB** of data, which is enough for about 80

minutes of audio or a few hundred documents and pictures. CDs are made of plastic and have a reflective surface that is read by a **laser beam inside a CD drive**. They were widely used in the for playing music, installing software, and storing small files. There are different types of CDs: **CD-ROM** (read-only), **CD-R** (recordable once), and **CD-RW** (rewritable multiple times). Today, CD usage has decreased because of faster and more convenient storage options like USB drives and cloud storage.

#### v. DVD technology

DVD stands for Digital Versatile Disc, and it is also an optical storage medium like a CD, but with much more capacity. A single-layer DVD can hold **4.7 GB** of data, and a dual-layer DVD can store up to **8.5 GB**, making it suitable for storing high-quality videos, movies, and larger software programs. DVDs use **laser technology with a finer beam** than CDs, which allows them to store more data on the same size disc. Just like CDs, there are different types: **DVD-ROM** (read-only), **DVD-R** (recordable once), and **DVD-RW** (rewritable). Although DVDs were very popular in the 2000s, their use has declined due to digital downloads, USB drives, and streaming services.

#### vi. Online storage

Online storage, also known as **cloud storage**, is a modern way of saving data on the internet instead of on a physical device. It allows users to upload, store, and access files through the internet using services like **Google Drive, Dropbox, OneDrive, and iCloud**. The data is saved on powerful remote servers managed by cloud service providers. One major advantage of cloud storage is that files can be accessed **from any device** (computer, mobile, tablet) and **anywhere in the world**, as long as there is an internet connection. Cloud storage is very popular today for both personal and professional use.

### 6.3 Backup Scheduling and Media Rotation System

**Backup scheduling** refers to planning when and how often data is backed up on a computer or network. It helps ensure that important files are regularly saved and can be restored if they are lost or damaged. Backups can be scheduled in different ways: daily, weekly, monthly backup and so on.

**Media rotation system** is the technique of backing up data to computer media such as HDDs, SSDs, etc. that uses the fewest possible media by using repeatedly. The main idea is to use multiple devices in proper order in rotation.

Benefit media rotation system:

1. It provides more than one back up
2. It reduces the risk of data loss if one device is damaged.
3. It saves money by reusing backup devices instead of buying new ones every time.

**Grand-father-son** (GFS) backup is a popular backup media rotation system technique used to manage data backups over time. It uses three levels of backup

Grandfather (Monthly Backup): At the end of the month, data backup is saved. These are stored for the longest time, sometimes for months or a year.

Father (Weekly Backup): At the end of the week, backups is saved as a weekly backup. These backups are usually kept for a month.

Son (Daily Backup): These are the backups taken every day. For example, from Monday to Friday, the system takes one backup each day. These backups are usually kept for one week.

## **6.4 Introduction to RAID**

**RAID** (Redundant Arrays of Independent Disks) is a technique that combines multiple hard drives or SSDs into a single system to improve performance, data safety, or both. If one drive fails, data can still be recovered from the others. RAID can be categorized into Software RAID and Hardware RAID.

### **Hardware RAID and Software RAID**

**Hardware RAID** uses a **separate physical device** (called a RAID controller) or a special built-in chip on the motherboard to manage the RAID system. Hardware RAID is managed **outside the operating system**. It offers **better performance** and **faster processing**. Hardware RAID is more expensive than Software RAID as Hardware RAID requires additional hardware.

**Software RAID** is managed by the computer's operating system (like Windows or Linux) without needing extra hardware. Software RAID is low cost as no additional hardware is required. Software RAID uses system resources as CPU and memory so that computers may be slower.

### **Levels of RAID**

#### **i. RAID 0:**

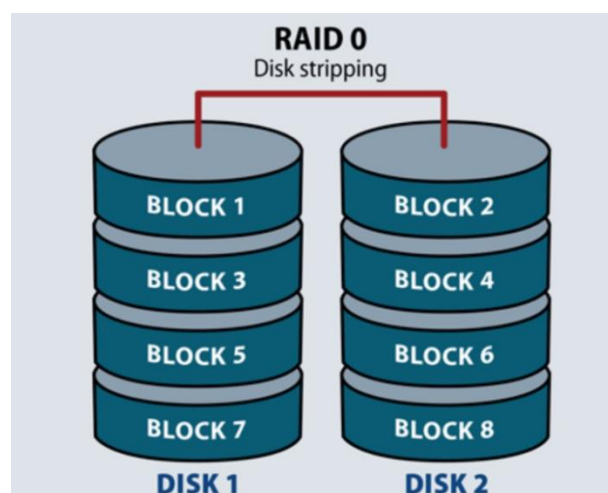

**RAID 0** is based on data striping. A stream of data is divided into multiple segments or blocks and each of those blocks is stored on different disks. So, when the system wants to read that data, it can

do so simultaneously from all the disks and join them together to reconstruct the entire data stream. The benefit of this is that the speed increases drastically for read and write operations

## ii. RAID 1:

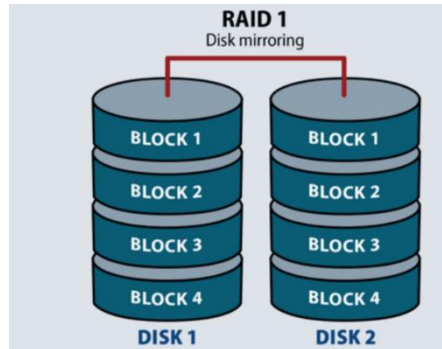

**RAID 1** uses the concept of data mirroring. Data is mirrored or cloned to an identical set of disks so that if one of the disks fails, the other one can be used. It also improves read performance since different blocks of data can be accessed from all the disks simultaneously.

## iii. RAID 5

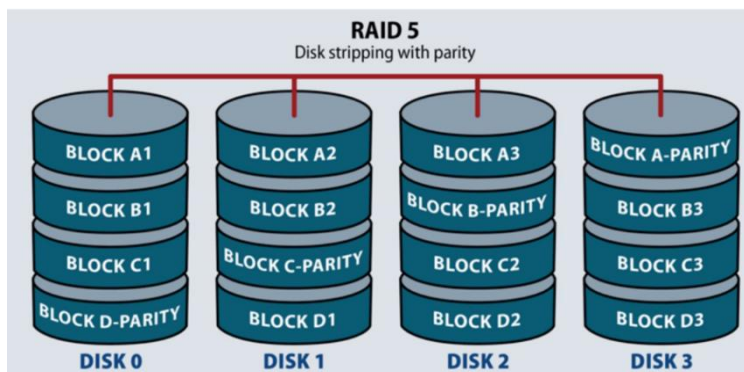

**RAID 5** is a type of RAID level which uses disk striping with parity. Data and parity are separated into blocks and striped evenly across the blocks. With the help of parity users can reconstruct data in case of a disk failure.

## iv. RAID 6

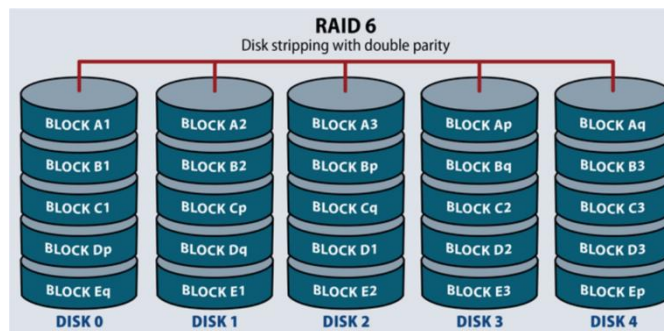

**RAID 6** uses double parity blocks to achieve better data redundancy than RAID 5. This increases the fault tolerance for up to two drive failures in the array. Each disk has two parity blocks which

are stored on different disks across the array. RAID 6 is a very practical infrastructure for maintaining high availability systems.

#### v. RAID 10

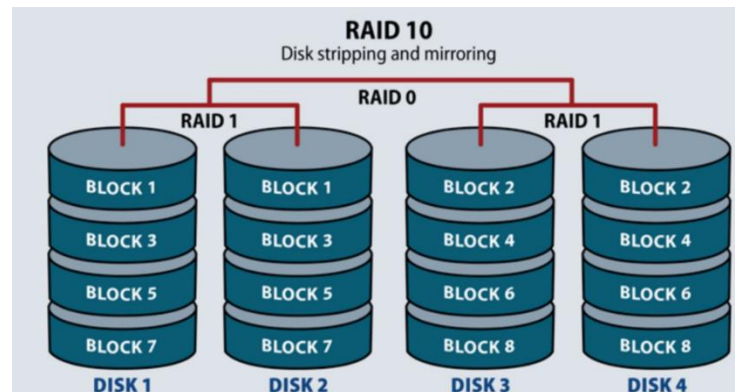

**RAID 10** combines both RAID 1 and RAID 0 by layering them in opposite order. Sometimes, it is also called as “nested” or “hybrid” RAID. If you are using a four-disk array, the system strips data across two disks, and the other two disks mirror striped disks, each holding half the data. This RAID level provides both high data security and high performance.

#### Summary

RAID 0 = striping

RAID 1 = mirroring

RAID 5 = single disk distributes parity

RAID 6 = double disk distributes parity

RAID 10 = combine mirror and stripe

#### 6.5 Recovery Technique

There are different types of recovery techniques. Some of them are explained below

- i. Bare metal recovery
- ii. Online disk backup
- iii. Continuous data protection

#### **i. Bare metal recovery**

**Bare metal recovery (BMR)** is a powerful recovery technique that allows you to restore a system even if the hardware has been completely wiped or replaced. The term "bare metal" refers to a completely empty computer or server with no operating system, drivers, or software installed. This technique restores the entire system, including the operating system, configuration settings, applications, and data, from a backup image.

## **ii. Online disk backup**

**Online disk backup** refers to backing up data from a local disk (hard drive or SSD) to a remote server or cloud storage over the internet. This technique is often used to protect against data loss due to disk failures, accidental deletions, or malware attacks. Online backups can be scheduled to occur automatically at regular intervals, making them convenient and consistent.

## **iii. Continuous data protection**

**Continuous data protection (CDP)** is an advanced recovery method where every change made to the data is saved in real-time or near-real-time. Unlike traditional backups that occur at fixed intervals, CDP enables the system to be restored to any point in time. This reduces the risk of data loss and is ideal for businesses with critical data operations. However, it may require more storage and system resources to track continuous changes.

